

**FIVE YEAR PLAN FOR CONTINUED OPERATIONS AS  
A RESOURCE TO THE COMMONWEALTH OF PUERTO RICO**

(FY 1982-86)

May 1980

## CONTENTS

	<u>Page</u>
PREFACE -----	1
INTRODUCTION -----	5
CEER ADMINISTRATION AND POLICIES -----	9
CEER AND OTHER PUERTO RICO RELATED INSTITUTIONS -----	13
ACCOMPLISHMENTS - PAST -----	17
ACCOMPLISHMENTS - PRESENT -----	19
PRESENT FUNDING -----	25
ON-GOING PROGRAMS -----	32
PROJECTED FUNDING AND SOURCES -----	33
FIVE YEAR PLAN PROGRAMS -----	38
FIVE YEAR (FY 1982-86) PLAN PROGRAM SUMMARY -----	41
OTEC -----	41
Biomass -----	45
Solar Energy Program -----	48
Environment -----	50
Others -----	52
1) Transportation and Conservation -----	52
2) System Energy Analysis -----	53
3) Institutional Miscellaneous -----	54
4) Public Awareness -----	54
5) Material Development -----	55
6) Fossil Fuels -----	55
7) Ethanol -----	56
8) Integrated Technological Assessment -----	56
9) International Programs -----	56
10) Miscellaneous -----	57
TOTAL BUDGET -----	57

## APPENDIXES

- A. Action Memorandum April 11, 1976.
- B. Members of Senior Advisory Committee on Energy and Environment.
- C. Members of the DOE Oversight Committee.
- D-1. The Role of CEER in the Master Plan Developed by the University of Puerto Rico.
- D-2. Institutional Policy Related to the Center for Energy and Environment Research: A Statement Approved by the University Board at its Meeting of March 26, 1980.
- E-1. Letters of Endorsement by the Planning Board and PREPA.
- E-2. The Relationships Between CEER and Society - Which Includes Institutional Base and Funding Sources as Recommended by the Energy Senior Advisory Committee.
- E-3. "The Burden of Competitive Grants," Science (16 Feb. 1979), Vol. 203, Num. 4381.
- F-1. Institutional and Development Programs (FY 1977-81).
- F-2a. Competitive Awards
- F-2b. Proposals Pending
- F-3. DOE Directly Sponsored Environment Research. Programs (FY 1977-81).
- G. Proposed Five Year Plan Programs (FY 1982-1986).

## P R E F A C E

This report presents basic information about the Center for Energy and Environment Research (CEER) of the University of Puerto Rico (UPR) and its research and development programs in energy and environment. It summarizes previous accomplishments and future projections, and emphasizes the uniqueness of CEER to contribute to the development of energy alternatives and interrelated environmental problems in Puerto Rico. The document provides a plan for the energy and environmental programs of CEER during the five year period corresponding to fiscal years 1982 through 1986. Major guidelines for the development of this plan stem from the following:

- 1) "La Política Energética de Puerto Rico - Un Primer Paso" (June 1979)
- 2) The National Energy Goals of the Federal Department of Energy (DOE)
- 3) CEER-A63, "Integrated Program Plan for UPR/CEER - FY 1980 and FY 1981"
- 4) The University of Puerto Rico Master Plan for 1980-1990
- 5) Yearly revisions by the Senior Research Advisory Committee on Energy and Environment

The report summarizes an assessment of the funding needed to continue operations and implement the five year plan. The plan and the funding requirements provide for a minimum program which will support basic research and development necessary for

more costly development and demonstration programs. The program per se will not solve the massive energy problems of Puerto Rico which consumes 70 million barrels of oil per year at an actual cost of over 2 billion dollars per year, and it will not solve the related environmental complications. In order to address effectively the massive energy problems of Puerto Rico, it will be necessary to plan large programs with funds in the order of ten times the level of funding requested herein. Such large programs have been addressed in other CEER publications.<sup>1</sup> These documents describe reasonable energy and environment research and development programs based on the capacity of the government of Puerto Rico to finance such programs in cooperation with DOE. CEER is the only institution in Puerto Rico and in the Caribbean capable of undertaking this task. It is an organization that has 23 years of experimental research activity funded by DOE and its predecessors, the Energy Research Development Administration, and the Atomic Energy Commission. The continuation of CEER operations beyond the termination of the present contract with DOE on September 30, 1981 depends upon the support of the Puerto Rican Government together with the support of DOE.

---

<sup>1</sup> CEER X-31 "R&D Program Needs for Energy Alternatives in Puerto Rico," Preliminary Report June 1, 1979.  
"Energy Analysis of P.R. Alternatives Energy Systems and Program Development Needs," in Press.

The role of CEER in the University of Puerto Rico Master Plan 1980-1990 for providing research as an essential component of academic activities is another important factor which has received careful consideration. Direct economic support from the University is also projected in the budget plans.

The proposed program also addresses the DOE goals of energy self sufficiency.

CEER is the only institution in Puerto Rico primarily responsible for the research and development of renewable energy alternatives which are significant to the island. It is one of the few institutions within the United States that focuses on both energy and environmental problems and on their reciprocal impact.

CEER is also the key institution on the island for integrating the research and development objectives in energy and environment at the University faculties, the Agricultural Experiment Station, such government of Puerto Rico agencies as the Office of Energy, the Electric Power Authority, and the Department of Health, in addition to Federal agencies such as DOE, the Department of Agriculture, HEW and the Institute of Tropical Forestry. Furthermore, CEER has become the vital link in the energy and environmental research and development efforts of several Latin American countries, particularly those in the Caribbean.

CEER possesses the unique capabilities necessary to carry on the development of energy alternatives and related environmental programs at the local, national and international levels.

CEER's major emphasis on projects which offer a good chance of producing commercially feasible alternative energy sources results in aid to the local industrial and agricultural sectors. This support can stimulate employment in the industrial sector through the production and installation of solar energy collectors and auxiliary equipment for utilization in solar heating for domestic, commercial, and industrial applications, including solar air conditioning, the manufacturing of photovoltaic cells and of electric and hybrid automobiles, and the production of materials for energy conservation. In the agricultural sector, the several programs that deal with sugar cane and energy grasses, and with the bioconversion programs, will stimulate economic activity in a sector that is about to undergo a complete reorientation in the coming decade.

CEER is a sophisticated research organization which has been brought to its present high level of effectiveness only after many years of hard work and the careful development of its funding capability. It now has the potential to participate actively in the search for the solutions to the most pressing problem of our generation. At the same time it will respond to the needs of the governmental, industrial, and agricultural sectors of the Puerto Rican society. Without the base funding requested in this document, CEER's continued existence will be in jeopardy, precisely at the moment when its contribution to our society will begin to be felt.

## INTRODUCTION

The world energy situation began to change drastically in the early 1970's when higher fuel oil prices were coupled with increased restrictions in the exploitation of the nuclear energy alternatives. The staff of the Puerto Rico Nuclear Center (PRNC) had to turn its attention to these problems by the mid 1970's. The registration in the nuclear program of both local and foreign students had dropped considerably, but there was an increased interest in the development of renewable energy alternatives. The increased industrial activity and the population growth with their accompanying environmental degradation contributed to changes in social, economic, technological and political attitudes. As a result, negotiations began in 1975 between the University of Puerto Rico (UPR) and the U.S. Energy Research Development Administration (ERDA), (previously the Atomic Energy Commission but now a part of the United States Department of Energy) to redefine the mission and goals of the PRNC. The PRNC had been in operation under contract with the AEC since 1957 under the Atoms for Peace Program and had grown into a meaningful research and development organization with a capability to undertake challenging assignments. As a result of the negotiations, UPR and ERDA approved an Action Memorandum dated April 11, 1976, (see Appendix A) providing for the creation of the Center for Energy and Environment Research (CEER) which would use the facilities and personnel of PRNC. There would be a major change in program scope toward



research on alternate energy and corresponding environment research and away from nuclear programs. CEER was established on July 1, 1976.

The new mission assigned to CEER included the following objectives:

- 1) To aid in the national effort to achieve energy independence and to contribute to Puerto Rico's efforts to achieve the same goal for itself.
- 2) To serve as the focal point for energy and environmental research and training in Puerto Rico, and to cooperate in research and training with other countries in the tropical and subtropical zones, particularly the Caribbean and Latin America.
- 3) To help Puerto Rico meet its manpower needs in energy and energy-related areas.
- 4) To continue training programs in Puerto Rico for students and personnel from the Caribbean and Latin America.

In order to achieve these objectives, CEER has:

- 1) Promoted strong research and training programs.
- 2) Attracted and developed University personnel to work on energy and environmental research.
- 3) Coordinated efforts which drew on expertise located in the University System.
- 4) Promoted academic excellence in the development of energy curricula and thus helped to promote cooperation between

the University, industry, government, and the community at large.

To help CEER achieve the transition from a nuclear center to a center focusing on energy goals, DOE established an Oversight Committee. The Committee held its first meeting with representatives of CEER and the University in November 1976, to review the transitional measures taken up to that time and to define plans for the future. All participants agreed that CEER's success would require close collaboration among CEER, ORO, ERDA (DOE), the technical program directors and the Oversight Committee, and continuous interaction between the Center and the University as a whole.

An Integrated Program Plan (FY 1977-82) dated February 1977 was prepared for the second meeting of the Oversight Committee in March 1977. This plan, with modifications, has served as a general guide for CEER's present programs. The modifications are contained in the revised CEER Integrated Program Plan for UPR/CEER FY 1980 and FY 1981, publication number A-63. The present document addresses the program plan for the following five year period (FY 1982-86).

CEER's experience in managing and administering first class scientific and technical research goes back to 1957 with its predecessor, the PRNC. CEER's first four years have enlarged and enriched its administrative, managerial and technical experience in dealing with renewable energy alternatives and related environmental research problems. As a result, CEER is the only

significant energy research and development facility in Puerto Rico, and it is one of the few in the United States, that focuses on both energy and environmental problems and on their interrelated impact.

The CEER facilities have an acquisition value of approximately \$12,000,000 and are located on four main sites: 1) the Río Piedras site (1 acre), adjacent to the UPR School of Medicine, 2) the Mayaguez site (20 acres), adjacent to the UPR Campus in Mayaguez, 3) the Cornelia Hill site (20 acres), on the coast south of Mayaguez which houses the Marine Ecology Division, 4) the Luquillo National Forest El Verde Facility in the Luquillo Rain Forest which houses the data acquisition field laboratory of the terrestrial Ecology Division and has 200 acres Use Permit.

A new site, a 15 acre lot in the north coast municipality of Toa Baja, has been added recently. This site is in the custody of the UPR, but it has been assigned to CEER for the development of an Experimental Station for field testing and demonstration of alternative energy sources such as solar, wind, and biomass-bioconversion.

The CEER research and Development Budget for FY 1980 is over \$4,000,000, including \$1,750,000 assigned by DOE for institutional, development, and programmed ecological research. The balance comes from funding for competitive research programs. The Puerto Rico Electric Power Authority (PREPA) environmental impact study about its future coal plant in

western Puerto Rico figures as one of the largest of these competitive funding programs.

During the current fiscal year, as agreed in the Action Memorandum of April 11, 1976, (Appendix A), the initiation of the physical facilities transfer by DOE to the UPR will begin. A gradual reduction of DOE funding (until such funding is completely eliminated by FY 1981) for support of facilities is also stated in the Action Memorandum. The successful continuation of CEER operations will largely depend on funds secured from the Government of Puerto Rico, from UPR, and from a possible future contractual relationship with DOE. This document addresses the minimum reasonable programs and the base funding requirements for continued operation. Without such base funding, even the competitive type research projects will be in jeopardy, since CEER could not be supported alone by competitive type programs which are on completely irregular time schedules. Furthermore, CEER could not meet its principal mission and goals.

#### CEER ADMINISTRATION AND POLICIES

CEER operates as a single unit within the UPR system, and its director reports directly to the President of UPR. UPR is an island-wide university with over 50,000 students concentrated in three large campuses, three four-year university colleges, and five regional colleges. It also has an agricultural research network and a cooperative extension service. The organizational structure of CEER is shown in Fig. 1.

CENTER FOR ENERGY AND ENVIRONMENT RESEARCH  
UNIVERSITY OF PUERTO RICO

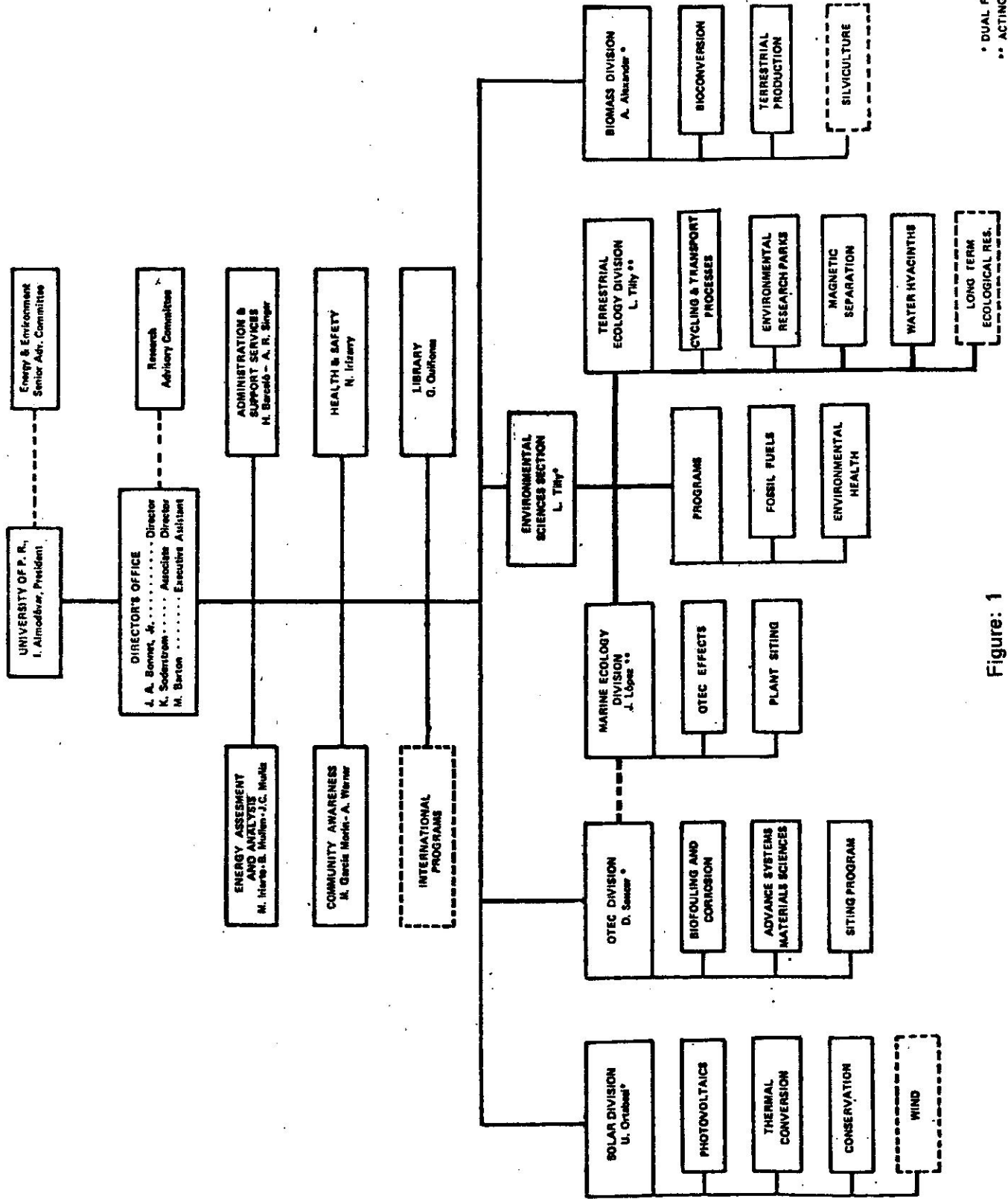

\* DUAL FUNCTION  
\*\* ACTING

Figure: 1

The CEER Director is appointed by the University President with the approval of both the Council of Higher Education and DOE.

As shown in Fig. 1, the President of the University is advised by a Senior Energy and Environment Research Advisory Committee. This Committee is composed of distinguished scientists from the United States and agency heads from the Government of Puerto Rico. Appointment to the Committee is made by the UPR President. The function of this Advisory Committee is to review yearly CEER research and development programs and make pertinent recommendations. These recommendations are given detailed consideration by the CEER administration and most have been adopted within the constraints imposed by budget, personnel and schedule limitations. Included on the Advisory Committee are the Director of the Puerto Rico Electric Power Authority, the Director of the Office of Energy, the Secretary of the Department of Natural Resources, the President of the Environmental Quality Board, and several outstanding scientists in the fields of energy and environment, one of whom (Dr. Melvin Calvin) is a Nobel Prize Winner. Appendix B is a list of the present members of the Advisory Committee on Energy and Environment.

The DOE Oversight Committee, briefly mentioned in the Introduction, is not shown in Fig. 1. This Committee, composed of DOE officials, overlooks the appropriate program schedules and makes recommendations about the CEER/DOE budget to the DOE Secretary. This budget plan, if approved by the Secretary, is

included in the overall DOE budget plan recommended to the President of the United States. Appendix C is a list of the Oversight Committee Members.

A DOE/CEER contract administrator is stationed in the Oak Ridge Operations Office (ORO). This contract administrator determines the proper accounting and administrative procedures that are to be followed.

The existence of the Advisory Committee and the DOE Oversight Committee insures that CEER programs are innovative, that they follow the state-of-the-art research, and that they address both Puerto Rico energy needs and the DOE energy self-sufficiency goals.

CEER administrative procedures for purchasing and accounting are independent from other UPR units. They are based on over 20 years of federal accounting and purchasing practices for research and development facilities. For example, purchase of equipment and materials for the various projects is authorized by the particular research project director, provided they are within the project budget, and only the additional approval of the CEER Director is necessary for purchases over \$500. Personnel hiring policies and fringe benefit policies comply with established UPR practices. However, there is no tenure within the CEER system. Hiring and lay offs will be directly related to the volume of work if a large portion of CEER programs rest on programs obtained through competitive contracts. A base funding of institutional programs

with combined competitively won funds is needed to assure the retention of specially trained scientists and technicians in the energy and environmental fields. Joint appointments of scientists and professors between the UPR and CEER is a flexible administrative procedure. In such joint appointments the professor draws a combined salary from both the UPR and CEER in proportion to the efforts devoted to each without losing University personnel benefits and tenure. The particular University campus is relieved of full salary payments and at the same time gains a better trained and more experienced research professor. The joint appointment arrangement is probably one of the most effective schemes for integrating CEER into the University System. It is the policy of the UPR President that CEER should be effectively integrated with the University scientific and technical facilities in order to make optimum use of resources and promote academic research. Appendix D contains a briefing entitled "The CEER and the UPR System's Master Plan" and a statement from the University Board about the Institutional Policy of CEER/UPR.

All of these administrative procedures enable CEER to carry on its mission for the development of renewable energy alternatives and the solution of related environmental problems.

#### CEER AND OTHER COMMONWEALTH OF PUERTO RICO

##### RELATED INSTITUTIONS

The Puerto Rico Government Agencies closely related to CEER missions of energy and environment are: 1) The Office of Energy,



2) The Electric Power Authority, 3) The Environmental Quality Board, 4) The Department of Natural Resources, 5) The Department of Health, and 6) The Department of Agriculture. The Institute of Tropical Forestry, a federal funded institution also works in close cooperation with CEER.

Act No. 128 of June 29, 1977, created the Puerto Rico Office of Energy. The Act empowered the Office of Energy to carry out and promote energy related research. Section 9 of the Act is related to coordination and it states: "Specifically, every research project shall be carried out in close coordination with the Energy and Environmental Research Center of the University of Puerto Rico".

The Act does not preclude the Office of Energy from carrying out its own research projects, but it recognizes the leadership of CEER in energy research and makes close coordination mandatory. At present the Office of Energy has no scientific research laboratories because no State Energy Offices are involved in direct research programs. Successful development of such facilities are normally possible only through integration with a University scientific community or with a highly technically oriented industrial facility. However, because of the tax incentive program, the industries in Puerto Rico are highly oriented to manufacturing while the research and development phases are usually done on the mainland. It takes years of effort and a large funding capability to develop a meaningful research organization. PRNC-CEER has compiled 23 years of

experience in research. It can fill the research needs of the Office of Energy through suitable administrative or contractual agreements.

The Puerto Rico Electric Power Authority (PREPA) is empowered by Act 142 of 1941 and its subsequent amendments to generate, distribute and sell all the electric energy in Puerto Rico. The Authority is bound financially by its Trust Indenture to invest its proceeds in a revenue producing manner. The proceeds are committed to meeting operating expenses, to retiring outstanding bond interest and amortization, to service for equipment depreciation, and, lastly, to a reserve capital improvement fund. No provision is made for investing in Research and Development of non-commercially available systems. The Authority must operate as a business and not as a research and development laboratory. However, some related research is recognized as proper for all electric utilities, but these projects are mostly related to current operating problems and to studies of future alternatives. The future energy alternatives studies permit the utility to solicit funds from federal agencies for project development. Since PREPA does not have an energy related research laboratory, CEER can complement the PREPA needs in this area. As it has in the past, CEER is now serving PREPA needs in the environmental energy related fields through contractual agreements. CEER has also been working on two PREPA contracts on OTEC commercialization and oceanographic studies. PREPA and

CEER have had a close and harmonious working relationship throughout the years.

The acts that created the Environmental Quality Board (EQB) and the Department of Natural Resources were reviewed. These agencies are of a regulatory and conservatory nature, and they are empowered to perform research related to their functions. No research policy related to the development of alternative energy sources is mentioned in the act. Although both agencies have laboratories, CEER environmental related facilities can complement their facilities through adequate contractual relationships.

The functions of the Department of Health and of the Department of Agriculture are also different from CEER's mission and goals. These agencies do not devote themselves to energy alternatives development. There are, however, certain CEER programs in environmental health, such as schistosomiasis studies and respiratory and gastrointestinal diseases energy-industry correlations, which are of interest to the Department of Health. As such, these programs complement Department of Health interests.

The main interest of the Department of Agriculture is in food production and not in biomass for energy. CEER initiative in biomass research complements other agricultural research programs.

The Industrial Development Administration (Fomento) is principally oriented toward industrial promotion. CEER can

provide technical advice and research support to Fomento industries in the field of energy and environment.

The President of the Planning Board of Puerto Rico and the PREPA Assistant Executive Director for Planning and Engineering have endorsed CEER plans for energy alternative and research needs in Puerto Rico. Copies of their letters of endorsement are included as Appendix E.

At its January 1980 meeting the CEER Senior Advisory Committee stressed the need for CEER to address the energy and environmental problems associated with Puerto Rico and its government agencies in addition to promoting high quality integrated research within the University system.

The relationship between CEER and society has been depicted by the Senior Advisory Committee in a line flow diagram which has been reproduced as Figure E-1 in Appendix E. The two main branches considered in such a relationship are, first, the applied research or problem solving mode interaction between the Office of Energy and local industries, and second, the basic science research or problem studying mode interaction between UPR campuses and international relations.

The programs described in this plan for continued CEER operations implicitly address these relationships.

#### ACCOMPLISHMENTS - PAST

During the 19 year period in which the Puerto Rico Nuclear Center (PRNC) operated a nuclear energy program, one of its main

accomplishments was the training of students in nuclear science and technology, nuclear medicine and health physics. Over 3500 students and scientists from 41 different countries participated in the various training and research programs. The participants were from countries throughout the world including India, Great Britain, Spain, Greece, Israel, Korea, Lebanon, Liberia, Kenya, Philippines, Germany, Hungary, Indonesia, Thailand, United Arab Republic, Turkey, South Africa, Malay, Taiwan and Japan. However, the largest number of participants were from Latin American countries, including Argentina, Bolivia, Brasil, Chile, Colombia (largest representation), Costa Rica, Cuba, Dominican Republic, Ecuador, El Salvador, Guatemala, Haiti, Honduras, Jamaica, Mexico, Nicaragua, Panamá, Paraguay, and Venezuela. Many of the former participants today hold important positions in government and private industry in their respective countries. The good will and friendship together with the academic and scientific accomplishments gained through these training programs was undoubtedly one of the major accomplishments of the PRNC.

Another area of major accomplishment was in ecological research in tropical ecosystems. Utilizing the tools of radio-tracers activation analysis and radiation perturbation, pioneer studies on the structures and functions of both marine and terrestrial rain forest ecosystems were conducted. These have provided the foundations for understanding the effects of

radiation on components of complex ecosystems and for the basic understanding of tropical ecosystems.

Also important in any summary of research accomplishments are the contributions to the knowledge of radiation effects on higher organisms, especially as they relate to human medicine.

#### ACCOMPLISHMENTS - PRESENT

##### Major Programs

The major accomplishment of CEER during its first three years of operation has been the establishment of a base for research and development programs for alternative energy sources and the solution of environmental problems associated with them. Baseline information has been collected, analyzed and reported for such important programs as the locating of an Ocean Thermal Energy Conversion (OTEC) plant off the southeast coast of Puerto Rico. CEER's interest in an OTEC Program in Puerto Rico is due to the fact that Puerto Rico has one of the best sites in the world for the location of an OTEC facility. OTEC plant baseline information attained thus far includes biofouling corrosion and material studies, and measurements of oceanographic environmental parameters.

A U.S. Navy Landing Craft Utility (LCU) has been reconditioned and equipped as a laboratory facility for OTEC research. The ship is presently moored approximately 1.5 miles south of Punta Tuna in Maunabo in 1000 meter deep water.

Experiments related to seawater surfactant systems and variability relationships to an open cycle FOAM OTEC System have been carried out at the Cornelia Hill facility in Guanajibo, Mayaguez.

Due to Puerto Rico's geographical location in a high insolation region with sufficient rainfall, good agricultural land, and the availability of agricultural research scientists, biomass-for-energy research programs have been undertaken by CEER and the Agriculture Experiment Station of UPR. Information has been gathered relevant to the development of agricultural technologies and to the optimization of harvesting large volumes of biomass and their economic and agricultural feasibility.

Bioconversion projects have been developed for producing methane from wastes. Biologically digested wastes mixed together with other biomass represents an attractive project for integrated energy and environment research in Puerto Rico. The results will be applicable to other areas, including the mainland. A demonstration project (waste digestion only) for the U.S. Army at Fort Buchanan has been developed by CEER and is now in operation. Important information has been gathered for the design of larger systems. Various methane generators, including newly designed systems to digest rum distilling waste, have produced important information. CEER is also working in cooperation with the owner of a large private hog farm in Ponce on a waste bioconversion project.

A solar research program cannot be logically developed unless solar radiation data is collected for the area under consideration. Solar radiation data has been continuously monitored by CEER measuring stations located in Mayaguez, Cabo Rojo, Lajas, Río Piedras, Ponce and Cataño. These data, both global and diffuse, are taken on an hour by hour basis, stored in a computer, and then mathematically modeled for practical use for research and design applications. Reports containing this important and vital information have been published and additional measuring stations are planned to provide more detailed information.

An evacuated compounded parabolic concentrator (CPC) for producing steam for industrial use has been developed by CEER to form the base of future industrial solar steam program. In addition, CEER has participated in the design phase of solar demonstration projects (photovoltaics and solar thermal).

The design, testing and evaluation of a solid dessicant air conditioning machine using silica gel has provided basic information for further study of this important system in the humid tropics. Air conditioning (especially for the commercial sector) is a significant portion of the electrical load in Puerto Rico.

In the ecology area, the establishment of basic information for future ecological studies related to planned energy production and utilization is the salient accomplishment.



The growth of the energy industry and the population increase have multiple effects upon the quality of the island's environment. An assessment of the effects of these developments upon representative island ecosystems has been the focus of CEER's Marine Ecology Research in the Guayanilla Bay studies and in the Terrestrial Ecology work on the Río Espíritu Santo basin. Current efforts have a similar ecosystem orientation but are directed in Marine Ecology toward assessment of the effects of the OTEC technology upon the ocean communities most likely to be effected. The Terrestrial Ecology program currently is developing the information needed to predict the fates and effects of materials which are being mobilized by the development of both conventional and alternative energy sources. Both the Terrestrial and the Marine Ecology Programs are also developing the ecological information needed for the assessment of a coal-fired power plant on the island.

#### Complementary Programs

The main efforts in the environmental health area in the past have been in controlling water quality and tropical disease transmission through aquatic systems (schistosomiasis). As a result of CEER's efforts, schistosomiasis in Puerto Rico has nearly been eradicated. Ongoing programs are establishing baseline information required in connection with correlation of respiratory diseases, gastrointestinal disorders and water quality common in Puerto Rico.

Materials programs have developed basic information related to the improvement and optimization of fuel cell electrodes, to the determination of properties of several solar selective surfaces, and to the degradation of the material of solar collectors and water heaters in the tropics. A base already exists in this area in that scientists and laboratories are now available for materials research.

On integrated technological assessment, energy analysis of various alternative energy sources has been made which will provide basic economic information and a period of competitiveness for the timely selection and development of alternative energy sources. The studies indicate that nuclear energy, on a cost basis only, is the lowest cost energy source for the rest of the century and beyond. Biomass and OTEC are strong contenders with costs lower than coal-fired power plants. The economics of photovoltaics look highly promising. The economic analysis of alternatives is a very important aspect of an energy program, and CEER is not overlooking this area.

Public awareness programs and training and education programs have received very little funding. However, CEER has conducted several successful programs including two three day international energy seminars in which scientists from Latin America participated. In addition, several summer energy-environment oriented training courses for local high school teachers and students have been conducted. Base information

has been accumulated for future use. CEER both sponsors and participates in many professional level seminars each year.

In the Transportation and Conservation Sector, significant economic and policy studies have been conducted, and data has been established for important future policy and decision making considerations. Over twenty five percent (25%) of Puerto Rico's net petroleum imports are used by the transportation sector. Present studies and experimentation are focused on the feasibility of use and development of electric or hybrid electric vehicles. Both of these vehicles show promise for substantial reduction in gasoline usage in the high density urban traffic which is typical in Puerto Rico.

To keep abreast of the latest developments in energy and environment research, CEER has sent scientists to visit various research laboratories for discussion of special projects and current research. Some of these laboratories visited have been: ORNL, JPL, SERI, ANL, KMS, SRL, BNL, Sandia, and LBL. In addition, CEER scientists have also visited such major university research laboratories as MIT, University of Colorado, Colorado State University, University of Florida, California Tech., UCLA, University of California-Berkeley, University of Michigan, and Carnegie Mellon University. Scholars from many of these laboratories and universities have visited and lectured at CEER.

Other accomplishments at CEER during the last four years include the success of the magnetic separation program (removal of pollutants from aqueous waste discharges); the tertiary treatment of waste water with water hyacinths; the use of sludge and hyacinth compost to produce methane; and joint efforts with the Venezuelan Government in research required to establish the practicability of using microbial oil stimulation methods in marginal wells producing extra heavy crudes and biodegradation of heavy crudes by means of selected microorganisms.

Meetings, conferences and seminars have been held with the Caribbean international community on energy and environment. Through these activities the expertise of CEER has been recognized and its assistance often requested. Contracts are being negotiated with Panamá, the Caribbean Development Bank (CDB), CARICOM, and the Venezuela Ministry of Energy and Mines.

#### PRESENT FUNDING

Because of limited funding, extremely careful planning was necessary to make these accomplishments possible. Approximately 3.5 million dollars were spent for all programs during the last fiscal year.

Funding sources for CEER programs generally fall into three categories:

- 1) Institutional and Development Funds

These funds are used to implement policy set by the general goals of CEER, the recommendations of the Senior Research

Advisory Committee, the Office of Energy document on Public Policy and other policies stated in the Introduction and in CEER Administration. These funds are not earmarked for specific projects by the funding sponsors, but are used according to broad guidelines. DOE is the principal funding source.

2) DOE Direct Support Program Funds

These funds are used for DOE supported projects such as environmental research for marine pollution, ship support, terrestrial ecology and an environmental research park. Another program currently supported by DOE is the decontamination of the Mayaguez Reactor Facilities.

3) Competitive Program Funds

These funds are obtained by submission of specific proposals on a competitive type of bidding. Awards normally depend primarily upon technical and scientific qualifications to perform the work rather than upon cost, although the latter is also considered. Competitive programs must respond to the customer's specific requirements. The general CEER goals of energy self sufficiency for Puerto Rico are not normally served through competitive bidding, except in the case of federal programs oriented toward alternative energy development in the Caribbean islands. Sponsors include such agencies as the Puerto Rico Office

of Energy, PREPA, local and national industries, organizations such as the National Science Foundation (NSF), the World Health Organization (WHO), the Solar Energy Research Institute (SERI), and the Department of Energy (DOE).

The field of competitive federal grants represents an overhead burden for research institutions since great efforts are spent writing proposals, a great number of which are usually rejected. Science Magazine (16 Feb. 1979: see Appendix E) reports that rejections average from about 20 to one to about four to one, depending upon the institution and the area of concern. "Competition has become increasingly keen and the proportion of proposals that can be funded has declined," the article states. According to this article 47,500 proposals were submitted in 1978 to various federal agencies. CEER has been unusually successful in winning federal grants because of its technical excellence as a research institution. More than half of the FY 1980 budget comes from competitive funding grants (see Appendix F-3 for Competitive Programs). The history of CEER's total budgets is summarized in Table 1.

TABLE 1  
 CEER's TOTAL BUDGETS  
 (Current-Thousand Dollars)

<u>FY-77</u>	<u>FY-78</u>	<u>FY-79</u>	<u>FY-80</u>
2367	3072	3500	4125

The funding history shows an overall average budget increase of 20% per year during the lifetime of CEER. (CEER projections will be based on a conservative growth of 10% per year.)

Figs. 2, 3, and 4 illustrate in graphic form the CEER total budgets, the breakdown of DOE component support, and the distribution of competitive funds. Figs. 2 and 3 show that the direct support from DOE has decreased continuously during the last three years; however, the increase in competitive funding has more than offset this effect and a continuous total increase has resulted. Fig. 3 shows the breakdown of DOE support funds. As Fig. 3 shows, the "training and education" and "base" program DOE funds have been eliminated completely. Fig. 4 illustrates the competitive funding by components and shows that competitive funding accounts for the healthy growth of the CEER budget. The difference between the "DOE Contractors" and the "DOE sponsored" competitive funds is that the first is assigned via direct relationship contracts and the latter via third party contracts with DOE.

The increase in competitive funded programs has one main advantage which is coupled to a disadvantage. The main advantage

FIGURE 2  
**CEER TOTAL BUDGET**  
(CURRENT DOLLARS)

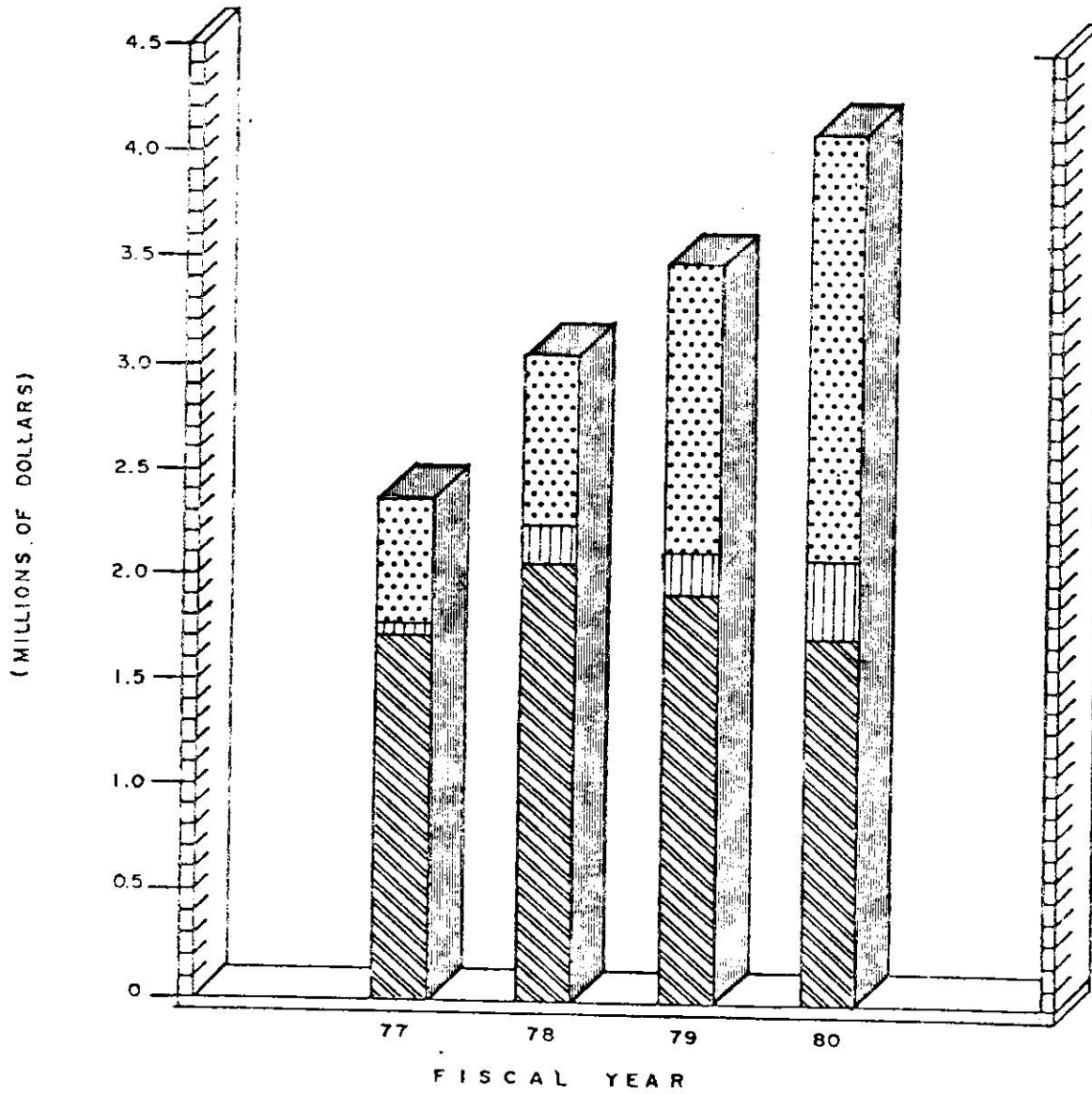
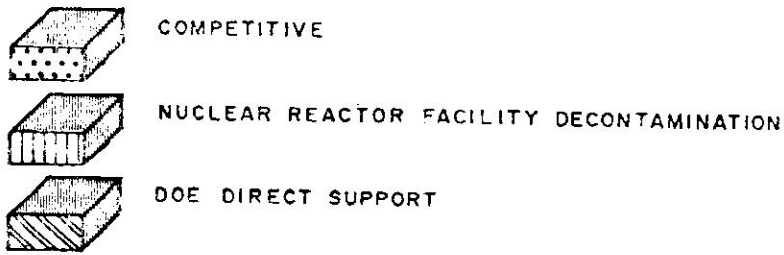



FIGURE 3  
DOE SUPPORT  
(CURRENT DOLLARS)

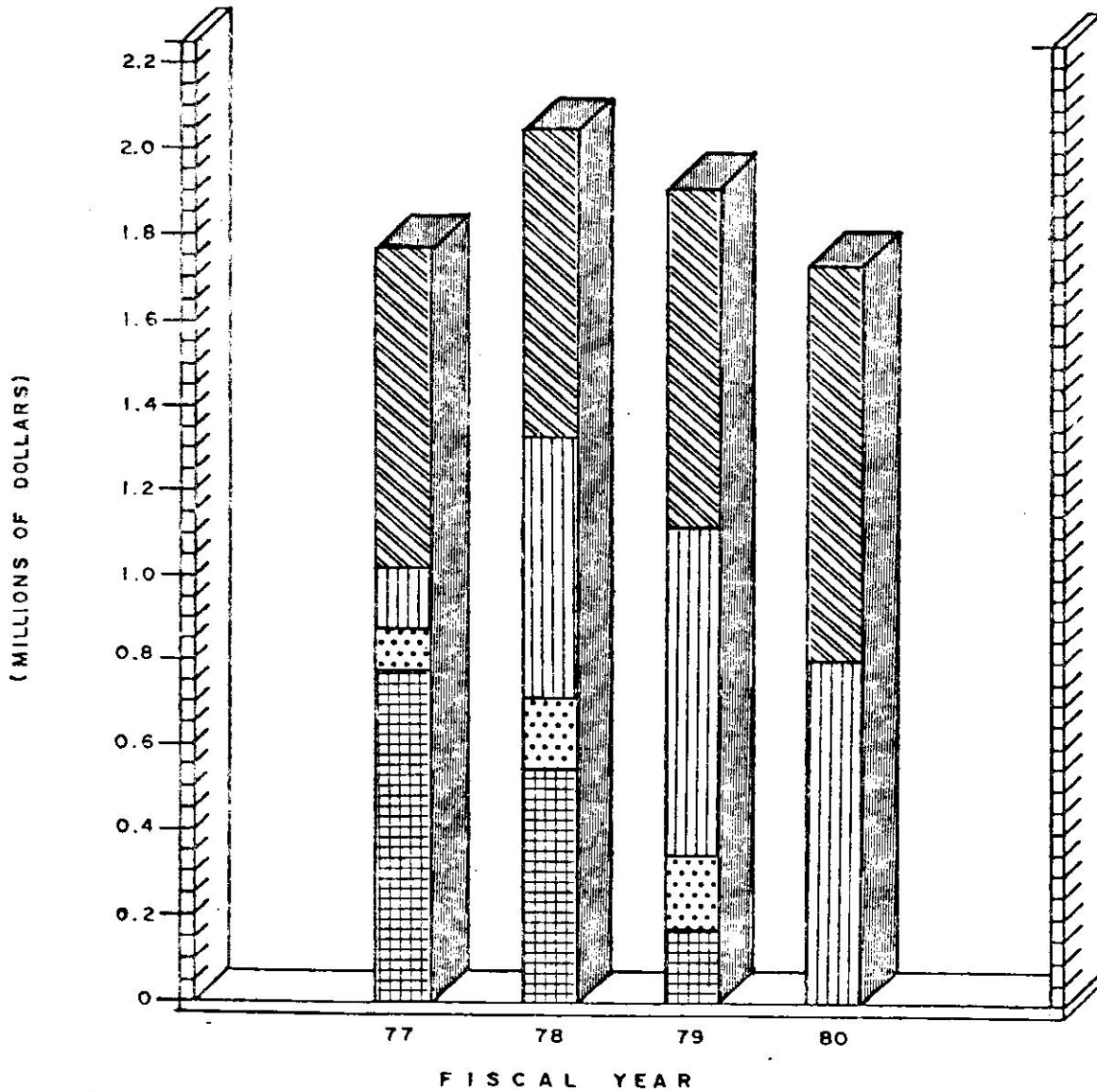
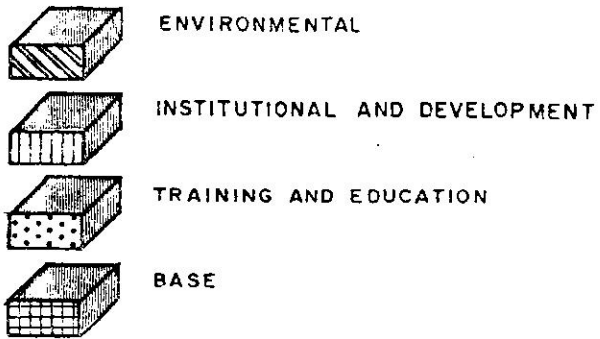
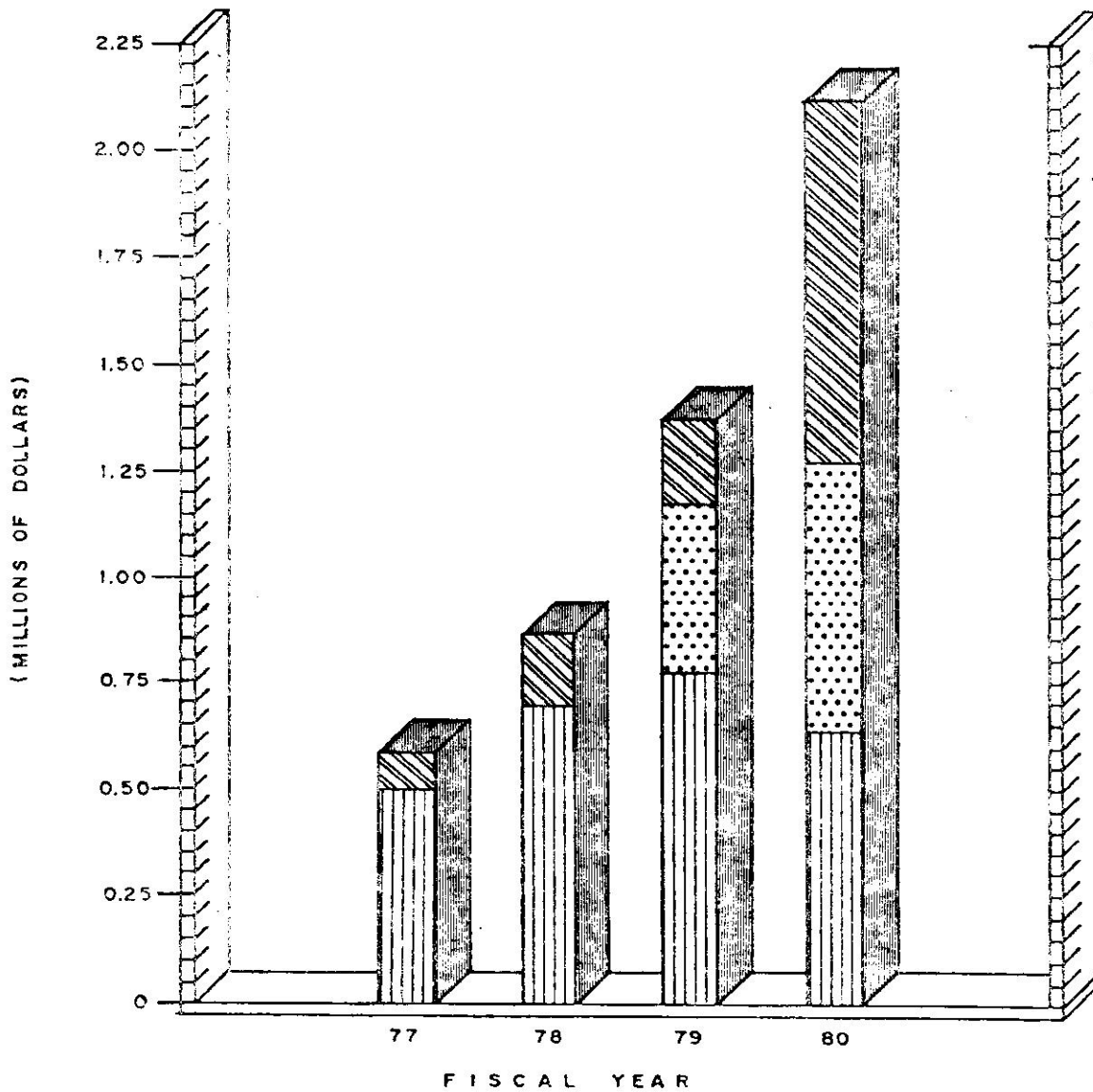
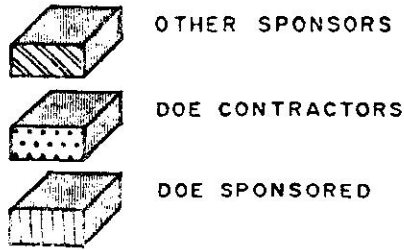

FIGURE 4  
COMPETITIVE PROGRAMS  
(CURRENT DOLLARS)



is that it points toward the technical competence of CEER. This funding helps in maintaining a fairly constant volume of work which keeps the technical staff busy. The main disadvantage is that too many competitively obtained programs make the CEER work schedule extremely unstable and sometimes divert attention from the long term institutional goals. Consistent institutional funding permits the development of new innovative programs and the retraining of personnel. Therefore, a healthy balance should be maintained. If the ratio of the institutional program budget plus DOE directly sponsored ecological program to the total budget were less than 0.5, then it might be argued that sponsor program budgetary interests are more important than institutional budgetary interests. It can be argued further that an ideal condition will be to keep this ratio at or just slightly above 0.5 for an adequate balance. At present, because of reduced DOE support and increased competitive activity, this ratio is 0.48. It should be pointed out that those competitive programs which advance institutional goals should be counted as part of the institutional funding for the purpose of the evaluation of this factor only.

#### ON-GOING PROGRAMS

CEER programs for the five year period 1977-1981, as revised, are described in "Integrated Program Plan for UPR/CEER FY 1980 and FY 1981," (CEER A-63). Appendixes F-1 and F-2 have

been reproduced from that document. They contain a detailed list of present programs, funding, locations and project leaders. Appendix F-3 provides a brief description of environmental research and the details of the funding sponsored directly by DOE.

#### PROJECTED FUNDING AND SOURCES

As indicated in the Introduction, the ownership of the CEER facilities will be transferred from DOE to the University, and there will be a reduction in DOE funding. This will require the UPR to assign funds for maintenance and upkeep of the facilities.

The present contractual relationship with DOE terminates in FY 81. A new contractual relationship may be entered into with DOE for continuing CEER support. This possibility will be greatly enhanced if the University and the government of Puerto Rico share the support of CEER with DOE. DOE has indicated that it will recommend the following funding:

TABLE 2  
PROPOSED FUNDING FROM DOE  
(Thousand Dollars)

<u>FY Year</u>	<u>Inst. &amp; Dev.</u>	<u>Env. Prog.</u>	<u>Decont.</u>	<u>Total</u>
81	850	1104	460	2414
82	500	1273	50	1823

Based on CEER's present and prior performance, it may be reasonable to assume that DOE will continue support under a new contract by appropriating Institutional and Development Funds. Because of regional factors,\* DOE may consider continued support to CEER for the Environmental (Ecology) program at the 1982 level shown in Table 3 with 10% increase per year. This assumption is based on the premise that both the University and the Government of Puerto Rico will contribute an amount at least equal to the DOE support for institutional funding.

Table 3, as well as the graphical description shown in Fig. 5, has been prepared after informal discussions among the University President, officials from the Government of Puerto Rico, DOE officials and the CEER Director. The level of funding suggested in Table 3 is the minimum possible for a meaningful research and development program. It is, however, far from the funding level required for a dynamic, aggressive energy and environment program. Table 3 calls for \$500,000 assignments from the Government of Puerto Rico for FY 81 and 82 and a 10% per year increase thereafter. A similar assignment is required from the UPR except for FY 81 in which the assignment is \$300,000.

Column 5 of Table 3 illustrates the total funding projection (including 10%/year growth) for the Institutional Programs.

---

\*The Luquillo Rain Forest is the only tropical forest owned by the U.S. Department of Interior, and is the only tropical ecological system under U.S. Flag where interaction between ecology and energy systems or components are presently being studied. The Punta Tuna site for the OTEC facility is unique in that it offers the advantage at one site where large OTEC plants can show economic competitiveness. Marine Ecology studies are part of the OTEC project.

TABLE 3

CEER BUDGET PROJECTIONS AND SOURCE OF FUNDS  
(Thousand Dollars)

(1)	(2)	(3)	(4)	(5)	(6)	(7)	(8)	(9)	(10)	(11)	(12)
FY	INSTITUTIONAL FUNDS				DOE		P. R. + DOE (5+6+7)	P. R. RATIO (3+4)/(8)	COMPETITIVE FUNDS (10)	TOTAL BUDGET (8+10)	BASE FUNDING RATIO (8)/(11)
	DOE	P. R. GOV.	UPR	SUBTOTAL (2+3+4)	DIRECT SUPPORT	OTHER					
80	800 <sup>1</sup>	---	---	800	935 <sup>1</sup>	260 <sup>2</sup>	1995	---	2130 <sup>3</sup>	4125	0.484
81	850 <sup>1</sup>	500	300	1650	1104 <sup>1</sup>	460 <sup>2</sup>	3214	0.249	2316	5530	0.581
82	500 <sup>1</sup>	500	500	1500	1273 <sup>1</sup>	50 <sup>2</sup>	2823	0.354	2547	5370	0.526
83	550	550	550	1650	1345	---	2995	0.367	2802	5797	0.517
84	605	605	605	1815	1480	---	3295	0.367	3082	6377	0.517
85	666	666	666	1998	1628	---	3626	0.367	3390	7016	0.517
86	733	733	733	2199	1790	---	3989	0.367	3729	7718	0.517

<sup>1</sup> DOE recommendations and approvals.

<sup>2</sup> Other DOE appropriations for Decontamination of Mayaguez Reactor Facilities.

<sup>3</sup> Additional funds (in the order of \$35,000) included to reflect recent DOE increased competitive assignments.

FIGURE 5  
**CEER FUNDING SCENARIO : FY 1980 - 86**

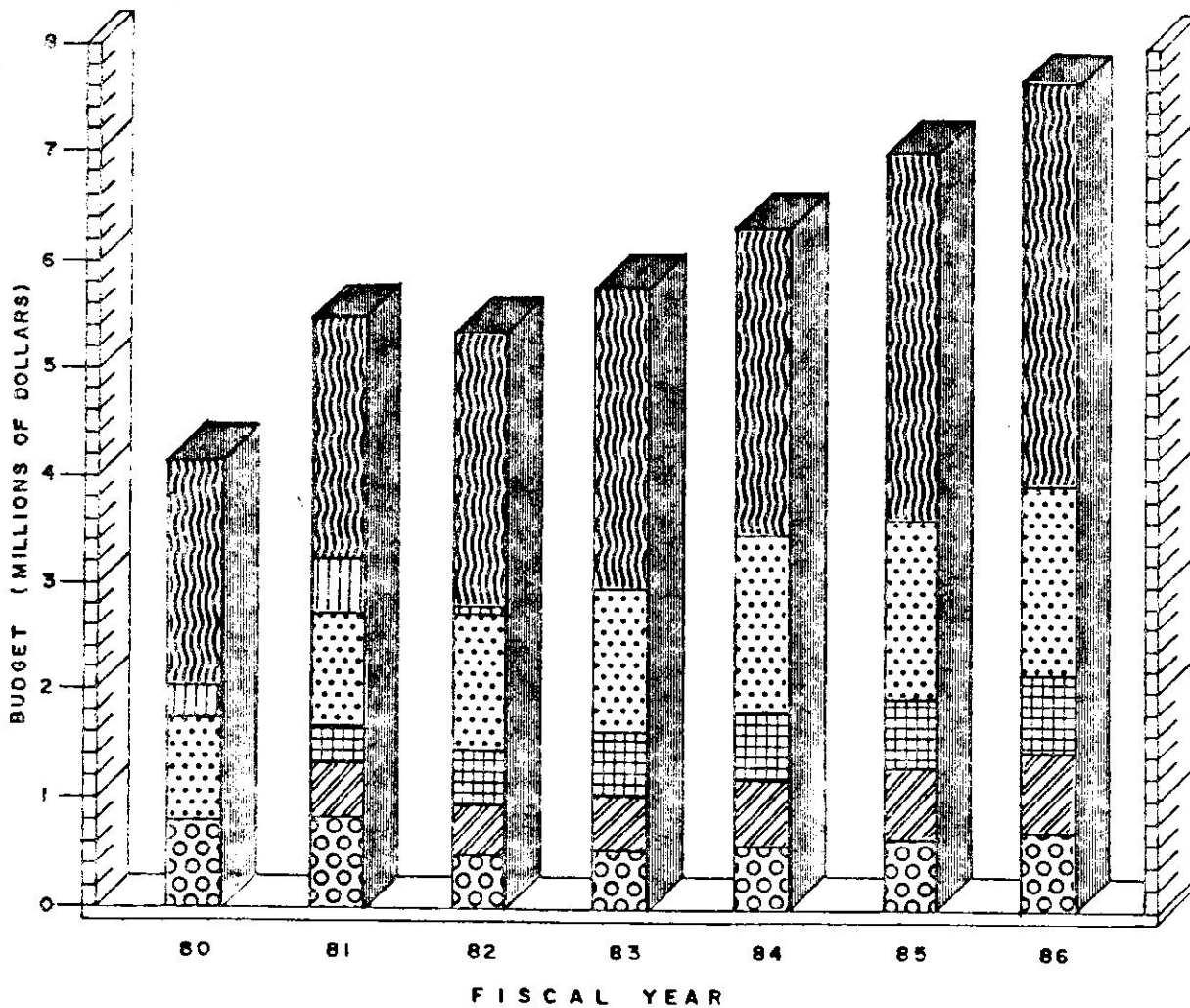
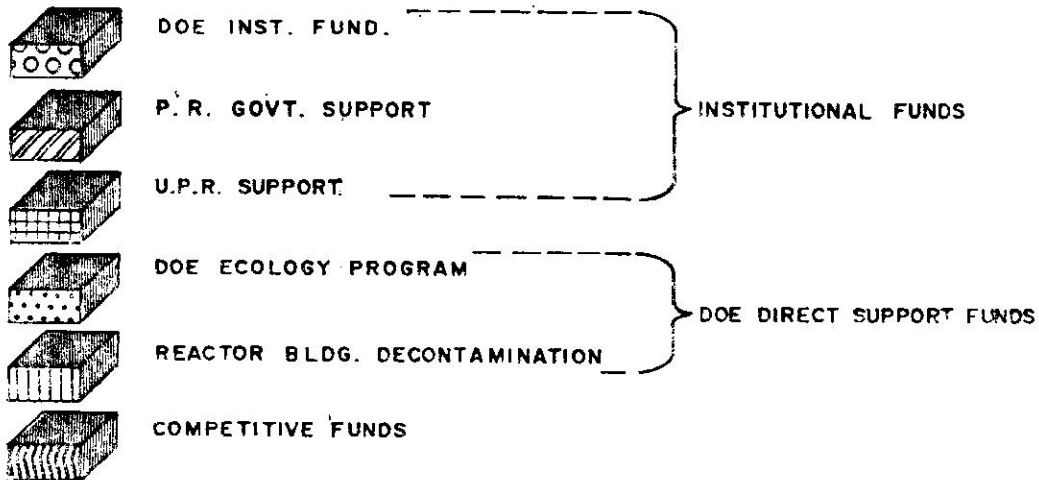

These programs address the institutional goals directly. Column 6 includes funds assigned by DOE to support specific environmental and ecological programs, and Column 7 includes the DOE sponsored decontamination program. It is expected that because of the unique tropical environmental conditions in Puerto Rico, DOE will continue to fund the environmental programs.

Column 9 of Table 3 shows the ratio of Puerto Rico support funds. It does not exceed 37% of the total.

Column 11 of Table 3 indicates the total projected CEER budget. This includes the additional component of competitive funding.

Competitive funding has been projected by taking the present level of competitive funding at CEER as a base. A comparison of columns 8 and 10 shows that after 1980 competitive fundings are slightly lower than the total of institutional plus direct DOE funding, which is a healthy, balanced condition. The last column in Table 3 indicates the ratio of institutional funding plus direct DOE sponsored programs to total funding. Except for the current fiscal year in which there are no Puerto Rican government funds involved, the base funding ratio is greater than 0.5 indicating that CEER base funding budget goals are planned so that they predominate over sponsored competitive programs. This again is a healthy balanced condition.

The funding projections detailed in Table 3 and the funding categories defined above are used for the CEER Five Year Program Plan (FY 1982-86). The yearly budgets of the plan are adjusted



to match the funds projected in Table 3.

#### FIVE YEAR PLAN PROGRAMS

The programs included in the five year period 1982-86 are focused on:

- 1) OTEC
- 2) Biomass
- 3) Solar Energy Programs
- 4) Environment
- 5) Others
  - a) Conservation and Transportation
  - b) System Energy Analysis
  - c) Institutional Miscellaneous
  - d) Public Awareness
  - e) Material Development
  - f) Fossil Fuel Research
  - g) Expanded Bioconversion Program-Ethanol
  - h) Integrated Technology Assessment
  - i) International
  - j) Miscellaneous (minor) Competitive Programs

Most programs are in harmony with the public policy document of the Office of Energy (June 1979). Fig. 6, reproduced from the Office of Energy Public Policy Document on Energy, indicates the various energy alternatives possibilities for Puerto Rico (Figure 6-a is the English translation.)

Appendix G, "Proposed Program Plan for the Five Year Period

Figure 6: Reprint from "La Política Energética de P.R.  
Un Primer Paso junio 1979" page S-14

Gráfica S-3  
Términos Cronológicos para Determinar  
Posibles Prioridades de Nuevas Fuentes Alternativas

Fuente	Período	Corto plazo (de 3 a 8 años)	Mediano plazo (de 5 a 20 años)	Largo plazo (después del año 2000)
ELECTRICIDAD	<ul style="list-style-type: none"> <li>- Desperdicios sólidos</li> <li>- Energía de viento</li> <li>- Calentadores solares de agua</li> <li>- Cogeneración</li> </ul>	<ul style="list-style-type: none"> <li>- OFEC</li> <li>- Bioconversion</li> <li>- Vapor por energía solar</li> <li>- Celdas solares fotovoltaicas</li> <li>- Acondicionadores solares de aire</li> </ul>	<ul style="list-style-type: none"> <li>- Concentradores solares</li> <li>- Celdas energéticas</li> <li>- Fusión</li> </ul>	
COMBUSTIBLE	<ul style="list-style-type: none"> <li>- Biomasa</li> <li>- Combinación de alcohol y gasolina</li> </ul>	<ul style="list-style-type: none"> <li>- Alcoholes puros</li> </ul>	<ul style="list-style-type: none"> <li>- Hidrógenos</li> </ul>	

FIGURE 6b

CHRONOLOGICAL TERMS TO DETERMINE  
POSSIBLE PRIORITIES OF NEW ALTERNATE SOURCES

PERIOD SOURCE	SHORT TERM (3 TO 8 YRS)	MID TERM (5 TO 20 YRS)	LONG TERM (AFTER YEAR 2000)
ELECTRICITY	<ul style="list-style-type: none"> <li>- SOLID WASTE</li> <li>- WIND ENERGY</li> <li>- SOLAR WATER HEATERS</li> <li>- COGENERATION</li> </ul>	<ul style="list-style-type: none"> <li>- OFEC</li> <li>- BIOCONVERSION</li> <li>- STEAM FROM SOLAR ENERGY</li> <li>- PHOTOVOLTAIC CELLS</li> <li>- SOLAR AIR CONDITIONERS</li> </ul>	<ul style="list-style-type: none"> <li>- SOLAR CONCENTRATORS</li> <li>- ENERGETIC CELLS</li> <li>- FUSION</li> </ul>
FUEL	<ul style="list-style-type: none"> <li>- BIOMASS</li> <li>- COMBINATION OF ALCOHOL AND GASOLINE</li> </ul>	<ul style="list-style-type: none"> <li>- PURE ALCOHOL</li> </ul>	<ul style="list-style-type: none"> <li>- HYDROGEN</li> </ul>

TRANSLATED FROM PAGE S-14 "LA POLITICA ENERGETICA DE PUERTO RICO, UN PRIMER PASO, OFICINA DE ENERGIA, OFICINA DEL GOBERNADOR DE PUERTO RICO, JUNIO DE 1979" (THE ENERGY POLICY OF PUERTO RICO, THE FIRST STEP, ENERGY OFFICE OF PUERTO RICO, OFFICE OF THE GOVERNOR OF PUERTO RICO, JUNE 1979.)

1982-86," is summarized below. This plan is based on the possible available funds as projected in Table 3. The program fund projections are 1980 dollars, and they do not include escalation. A 10% per year increase has been included to reflect program growth. Table 4 illustrates the proposed institutional fund distribution of the various proposed programs. Table 5 illustrates the funding of the "DOE Directly Supported Ecology Programs." These programs are mainly ecology type programs. Table 6 illustrates the projected and expected competitive lump sum distribution per program. No detailed program distribution is indicated in Table 6 because of the uncertainty involved in predicting detailed competitively funded programs.

#### FIVE YEAR PLAN (FY 1982-86) PLAN PROGRAM SUMMARY

##### OTEC - Ocean Thermal Energy Conversion

This concept utilizes the temperature differentials between surface sea water and sea water 1000 meters deep. This temperature differential is about 20°C. The surface waters are used to evaporate a low boiling working fluid such as ammonia or propane in an evaporator. The working fluid vapors expand through a turbine generator to produce useful work. The fluid vapors are condensed with deep sea water in a condenser to complete a closed cycle.

Puerto Rico has one of the best sites of the world for developing this concept. One thousand meter deep water is found within 1.5 miles from the shore off Punta Tuna in Maunabo. This

TABLE 4

PROPOSED CEER PROGRAMS INSTITUTIONAL FUNDING  
FY (1982-86)

Funding Source Indicated in Table 3, Columns 2-5  
(Thousand Dollars)

	80	81 <sup>(1)</sup>	82	83	84	85	86
I. <u>OTEC</u>							
Evaporator		75	75	85	100	115	130
Condenser	35	125	125	165	200	235	270
Siting	--	50	50	50	50	50	50
Misc.	--	50	50	50	50	50	50
TOTAL	35	300	300	350	400	450	500
II. <u>BIOMASS</u>							
Hydrocarbon Plants	--	25	25	35	40	45	50
Silviculture	3.5	40	40	50	55	60	65
Direct Firing	--	120	150	155	170	175	194
Bioconversion	135.4	185	75	50	25	15	10
Misc.	36.5	30	10	10	10	5	5
TOTAL	175.4	400	300	300	300	300	324
III. <u>SOLAR</u>							
Data		20	16.5	20.0	20	22	10
Serv. Hot Water	45.0	10	8.5	10.0	--	--	--
Ind. Steam	69.0	100	100.0	100.0	100	125	125
Solar Space Cooler	34.5	40	50.0	75.0	100	125	150
Photovoltaics		50	100.0	125.0	150	175	225
Misc.	34.5	55	25.0	20.0	30	28	40
TOTAL	183.0	275	300.0	350.0	400	475	550
IV. <u>ENVIRONMENT</u>							
Ecology - Misc.	--	40	50	75	100	125	150
Health - Respiratory Dis (air)	17.2	25	25	25	25	25	25
Gastro Dis (water)	23.0	30	20	20	20	20	20
Misc.	68.3	30	30	30	30	30	30
TOTAL	108.5	125	125	150	175	200	225
V. <u>OTHERS</u>							
a) <u>CONSERV. &amp; TRANSP.</u>							
Hybrid Vehicle	30	150	75	75	85	85	85
b) <u>SYSTEM ENERGY ANALYSIS</u>							
Energy Analysis	34.5	50	50	35	40	40	40
Policies Studies	16.0	25	25	25	15	15	15
Misc.	--	25	25	15	10	10	10
TOTAL	50.5	100	100	75	65	65	65
c) <u>INSTITUTIONAL MISCS.</u>	217.6	300	300	350	390	423	450
TOTAL INSTITUTIONAL	800.0	1650	1500	1650	1815	1998	2199

(1) As revised in the present document CEER-A63 biannual (80-81)  
Plan is altered as per this revision.

TABLE 5

DOE DIRECTLY SUPPORTED  
ECOLOGY PROGRAMS

(Details in Appendix G)

Study Areas	80*	81*	82	83	84	85	86
A. Ecosystem Structure and Process Studies			625	584	772	912	1013
B. Resource Management Studies			380	490	450	456	473
C. Ecological Effects Studies			268	271	258	260	304
TOTAL	935	1104	1273	1345	1480	1628	1790

\*See Appendix F-3 for detailed breakdown of programs for FY 1980-81. Study areas here indicated commence in FY-1982.

TABLE 6

BUDGET PROJECTIONS FOR COMPETITIVE FUNDED PROGRAMS

(Thousand Dollars)

	80 (1)	81 (2)	82	83	84	85	86
1. OTEC	683.9	700	700	750	800	850	1000
2. Biomass	407.7	400	400	400	400	350	350
3. Solar	32.5	150	150	175	200	225	450
4. Environment	736.3	500	500	550	600	650	900
5. Others							
d. Public Awareness	10.0	125	150	123	140	155	167
e. Material Dev.	--	100	125	227	327	390	495
f. Fossil Fuels	105 (4)	125	127	200	225	300	
g. Ethanol	--		220	220	225	240	--
h. Integrated Technological Assessment	--	125	125	135	145	205	225
i. International	--	--					
j. Miscellaneous Projects (3)	154.6	91	50	22	20	25	142
TOTALS	2,130 (4)	2,316	2,547	2,802	3,082	3,390	3,729

(1) See Appendix F for detailed list of present competitive programs.

(2) Present contracted work for 1981 is approximately \$855.5 thousand (Appendix F). Additional competitive funding is projected.

(3) Miscellaneous project might include expansion of those listed in Appendix F plus others not listed as requested by sponsors. Indicated figures were estimated so as to reflect possible competitive funding trends.

(4) Figures recently revised to reflect additional funding in fossil fuel research.

was recognized by the Puerto Rico Electric Power Authority (PREPA) back in 1966 when preliminary studies were made and a research and funding program was recommended.

The ongoing OTEC program at CEER involves corrosion analysis, studies of biofouling in the evaporator, and site characterization investigation including determination and measurement of oceanic parameters, such as water current, biota, and water chemistry. The program proposes to continue the present studies related to the condenser portion. This requires a pipe one kilometer long and a pump system. CEER is presently operating an OTEC platform ship at Punta Tuna. This ship is a reconditioned U.S. Navy Land Craft Utility (LCU) which has been equipped with laboratory facilities. Operational cost of this facility is \$500,000 per year. The projected institutional funding for this program is illustrated in Table 4, Part I, and the possible competitive funding is projected in Table 6.

### Biomass

#### A. Existing Programs

Plant materials can be produced locally as a renewable source of fuels and chemical feedstocks to substitute imported fossil fuels. Biomass research on tropical grasses and sugarcane was initiated in 1976. Total accumulated research expenditures today exceed \$1,000,000. The project objectives have been: a) determination of the agronomic and economic feasibility of mechanized, yearly production of solar-dried biomass through



the intensive management of sugarcane and napier grasses as tropical forage, and b) examination of alternate tropical grasses as potential sources for intensive biomass production. This program is being developed with funds competitively obtained from DOE. Funding for this program will probably be continued on a competitive basis at about \$400,000 per year.

#### B. New Programs

##### 1) Hydrocarbon Bearing Plants

Plants of the Euphorbias, Aschepiais and Guayale families thrive in Puerto Rico in dry and salty soil regions. These plants manufacture hydrocarbons, mainly polymers of isoprene, which constitute an adequate hydrocarbon fuel or chemical feedstock. The principal objective of such a program will be: a) the identification of the most promising plants for detailed selection and breeding, and b) the determination of the agronomic and economic feasibility through intensive management of hydrocarbon bearing plant farming. The level of proposed funding is shown in Table 4.

##### 2) Silviculture

The production of woody biomass (silviculture) as a renewable energy source offers a challenge for a forest industry in Puerto Rico. In this program woody species serve as a partial substitute for fuel rather than imported timber. Species regarded as "junk" insofar as quality wood products are concerned have a new economic potential. Members of the genus Albizia and of the

Eucalyptus robusta are in this category. The primary objectives of this program are: a) the determination of dry matter producing potential, b) the determination of yield potential of superior species, and c) the completion of an economic analysis.

This program will be carried out in close cooperation with the Institute of Tropical Forestry. The proposed funding requirements are shown in Table 4.

### 3) Direct Firing of Biomass

Solar dried Biomass is contemplated as a fuel for direct firing in conventional waterwall steam boilers in central electric power plants. CEER economic studies indicate that biomass can compete economically with imported coal. The CEER contribution in a direct firing program will be to provide the required expertise in the development and operation of a needed pilot project. CEER funds of from \$120,000 to \$200,000 per year can be assigned from the proposed budget for a five year period.

The objective of the direct firing program is to convert an existing sugar mill to handle 1000 tons of biomass per day, to determine the logistics of production, drying, transportation, storing and burning of biomass to assess the technical modifications to boiler handling and burning equipment, and to study the characteristics of particules and gaseous emissions. The capital investment made by government for mill modification is estimated at nearly 5 million dollars and the total 6 year program will cost \$13 million dollars. The CEER

contribution from the Institutional and Development program is proposed to be \$1.139 million in the 1981-86 period. The large capital investment required must be secured through appropriate legislative action.

#### 4) Bioconversion

Methane gas is produced in the anaerobic digestion of wastes, residues, and biomass. At present, continuously operating bioconverters are those using water hyacinths, rum waste and cafeteria refuse. The first two units are operating at CEER and the cafeteria waste converter is operating at Fort Buchanan Army Base in cooperation with the Army Environmental Research Program. One of the main objectives of the Biomass Program is to demonstrate the technical and economic feasibility of fermentative biogas production from locally available biomass in decentralized, low technology operations. Other specific objectives are listed in Appendix G. The institutional funding for the Bioconversion Project is shown in Table 4, and the possible competitively secured funding is indicated in Table 6.

#### Solar Energy Program

Incident solar energy on the surface of Puerto Rico arrives at an average rate (day and night, year around) of more than 5 kilowatt-hours (kwh) per square meter per day. Over a course of a year, one square kilometer receives 1.825 billion kwh. Accordingly, 82 square kilometers of land, dedicated to solar photovoltaic cells solar energy generation at 10 percent efficiency, could meet

the entire Puerto Rico power generation requirement for 1979. Subtropical dry forest land with extremely high solar insolation levels occupies more than 1500 square-kilometer of the southern region of the island.

The goal of the solar energy program is to help to develop commercially attractive and environmentally acceptable applications of solar energy at the earliest feasible time. Solar energy is readily converted into thermal energy, electricity and clean fuels through conversion processes and systems that are accepted as technically feasible.

During the proposed five year program CEER's solar involvement will emphasize:

- a) Continuation of the systematic solar data acquisition throughout Puerto Rico,
- b) Research and development in solar cooling in a tropical environment,
- c) Generation of electricity from photovoltaic conversion of sunlight,
- d) Industrial solar process heat,
- e) Research in solar materials.

Specific objectives and milestone charts for these programs are contained in Appendix G. The Solar Division will also participate in a broad alternative energy resources assessment that will involve all other divisions of CEER.

During the five year program emphasis will be expanded to involve private industry in all phases of solar research and development, and demonstration programs in order to accelerate the use of solar technology in the commercial sector. Institutional and competitive funding levels for the solar program are shown in Tables 4 and 6.

### Environment

#### 1) Ecology

Energy production results in the output of materials, waste energy and direct environmental disturbance which have potential for altering the natural systems which support man. CEER Ecology Programs focus on the relationship between anthropogenic outputs and the natural systems that receive them. Forming the baseline for understanding how the natural processes may be disrupted is a set of studies of Ecosystem Structure and Process. These include studies of the ocean environment near an OTEC operation, terrestrial and marine studies for the siting of a coal-fired power plant, and investigation of the cycling and transportation of carbon, sulfur, nitrogen, and phosphorus likely to be activated in energy development in tropical terrestrial ecosystems such as the Luquillo Rain Forest. Efforts are underway to organize an environmental research park at the Luquillo Experimental Forest Service Institute of Tropical Forestry to make environmental assessments.

Ecological Effects studies now in progress are aimed at understanding impacts of sediments and metals discharged from waste heat rejection systems upon representative marine organisms. Plans include measuring the ability of natural systems to process various wastes normally and without loss of integrity.

Resource Management Studies include efforts to clean wastes by using water hyacinths as an energy source.

Wildlife resource management studies are exemplified by the research in progress upon the commercially important land crab, which is being threatened by habitat reduction and heavy metal releases associated with land development and use.

During FY 1982-86 all three sub-programs indicated in Table 5 will be continued and expanded. Emphasis will be placed on specific effects studies and upon measurements of the ability of ecosystems to absorb and process man's products.

In addition to the DOE Supported Ecology Programs illustrated in Table 5, some Institutional and Developmental funding for ecology type programs have been included in Table 4 under Ecology-Miscellaneous. This funding is expected to be used for proposal writing for competitive funding, and for developing new approaches based on data processing of existing programs and information.

## 2) Environmental Health

This program is also included under the general category of Environment. Environmental Health Programs have been reduced considerably at CEER during the last two years.

but the technical and scientific expertise is capable of generating useful and needed competitive programs.

The correlation of respiratory diseases with air pollution, and the correlation of gastrointestinal diseases with water quality are among the ongoing health programs at CEER. Such studies become more important as Puerto Rico becomes more industrialized. Tables 4, 5, and 6 indicate the funding levels for these environmental projects. Appendix G contains more detailed information.

#### Others

##### 1) Transportation and Conservation

The main effort in this area is on electric and hybrid vehicle test and demonstration program for conservation. A hybrid vehicle has already been ordered by CEER for this program and an electric vehicle is already being tested. The project objectives include:

- a) development of a Driving Cycle for Urban Puerto Rico,
- b) hybrid vehicle power train optimization,
- c) demonstration for public awareness,
- d) motor-generator developments.

A comprehensive energy conservation plan for the University has been prepared by CEER. It is expected to serve as a model for other institutions. The plan will be revised and updated as required. Appendix G discusses these aspects in detail.

Proposed funding for Transportation and Conservation is shown in Table 4.

2) System Energy Analysis

CEER proposes to continue its system energy analysis programs which can be classified as follows:

- a) energy demand analysis,
- b) Engineering-economic studies of energy systems,
- c) socio-economic studies of energy systems,
- d) socio-economic studies of energy conservation,  
including transportation energy conservation.

The energy demand analysis will include econometric studies of energy demand by sector - residential, industrial, commercial, and transportation. Forecasts of energy demand and estimates of price elasticities will be emphasized.

The engineering-economic studies of energy systems include a continuation of economic systems of alternate and conventional energy sources including biomass, OTEC, wind, photovoltaics, oil, coal and nuclear. CEER developed computer programs will be used as the base to program the funds required for the timely development of the energy alternatives and for their commercialization.

The socio-economic studies of energy systems will include evaluation of macro-economic impacts of alternate energy systems on employment and production and on the balance of trade as well as an analysis of both the incentives and the barriers to their adoption.



The socio-economic studies of conservation will emphasize the transportation sector and will include systems management, analysis, and updating of policy scenarios for energy conservation.

Close coordination will be maintained with Puerto Rican government agencies such as PREPA, the Office of Energy, the Planning Board, the EQB, Fomento, the Department of Natural Resources, and the Department of Transportation. Encouraging comments from the Planning Board and from PREPA on preliminary work performed by CEER in this area have been received and are included in Appendix E.

Appendix G discusses the details of these programs and Table 4 illustrates the proposed funding.

### 3) Institutional Miscellaneous

Institutional miscellaneous funds include library and scientific support, expenses for visiting scientists required for technology transfer to local technical and scientific personnel, the preparation of proposals for program support, and explanatory research of novel ideas. The Senior Advisory Committee has recommended that these funds should be between 10-25% of the institutional funds. Funding levels are shown in Table 4.

### 4) Public Awareness Program

This deals with community education through seminars, lectures to school teachers, compilation and publication of

energy related information to the general public, use of mass media communication systems, and community participation or involvement in the educational process. Projected competitive funding levels are indicated in Table 6.

#### 5) Material Development

Material development deals with the testing and development of solar materials in a tropical humid environment. It encompasses the establishment of a data bank on solar materials for research and development purposes, the testing for actual material degradation from the sun, the wind and the general environment, the study of ferroelectric materials structures for direct electric conversion, fuel cell electrode surface studies, electro, plastic and material applications, hydrogen production via solar energy, and solar collector surfactant cleaning materials. Table 6 indicates expected competitive funding levels.

#### 6) Fossil Fuels

This area deals with the biodegradation of high sulfur-heavy crude oils and the application of physical, chemical and biological forces to enhance oil recovery. The government of Venezuela is helping to support this work. A total funding of approximately \$331,000 of competitive DOE funds has been spent in the last three years in this area. Table 6 shows the projected competitive funding levels. Appendix G contains the details of the program.

#### 7) Ethanol

Production of ethanol from sugarcane molasses promises to be a viable substitute for gasoline. A mixture of 10% ethanol with gasoline can be used without changing carburation adjustment in modern internal combustion vehicles. This program proposes to use existing facilities at the UPR Rum Pilot Plant, and a proposal has been submitted to DOE. Competitive funding levels are shown in Table 6.

#### 8) Integrated Technological Assessment

Solar Hot Water Systems, Small Wind Driven Turbines for domestic use, and a photovoltaic small community program is contemplated in this area. These projects are to be developed in cooperation with various communities, and technical assistantship and leadership will be provided by CEER. Competitive funds assigned to this project are shown in Table 6.

#### 9) International Programs

This area encompasses Technology Transfer to less developed countries (LDC) in the Caribbean and Latin America in the areas of energy alternatives and related environmental problems, and assessment of material resources for potential development. CEER has recently submitted proposals to Panama and to the Caribbean Development Bank in these areas. It has also submitted a proposal on OTEC for Developing Countries to the U.S. State Department.

10) Miscellaneous (Competitive Programs)

Small miscellaneous projects obtained under competitive basis.

TOTAL BUDGET

Table 7 and Figure 7 summarize the general total funding projection by program areas. The largest funded program is Environment followed by OTEC, if Others is excluded. Biomass and Solar are approximately at the same funding level.

TABLE 7  
GENERAL FUNDING DISTRIBUTION BY PROGRAMS  
(Thousand Dollars)

FISCAL YEAR	80	81	82	83	84	85	86
<u>OTEC</u>							
PR + DOE	35	300	300	350	400	450	500
COMP.	683.8	700	700	750	800	850	1000
TOTAL	718.9	1000	1000	1100	1200	1300	1500
<u>BIOMASS</u>							
PR + DOE	175.4	400	300	300	300	300	324
COMP.	407.7	400	400	400	400	350	350
TOTAL	583.1	800	700	700	700	650	674
<u>SOLAR</u>							
PR + DOE	183	275	300	350	400	475	550
COMP.	32.5	150	150	175	200	225	450
TOTAL	215.5	425	450	525	600	700	1000
<u>ENVIRONMENT</u>							
PR + DOE	1043.5	1229	1398	1495	1655	1828	2015
COMP.	736.3	500	500	500	600	650	900
TOTAL	1779.8	1729	1898	2045	2255	2478	2915
<u>OTHERS</u>							
PR + DOE	558.1 <sup>1</sup>	1010 <sup>1</sup>	525 <sup>1</sup>	500	540	573	600
COMP.	269.6	566	797	927	1082	1315	1029
TOTAL	827.7	1576	1322	1427	1622	1888	1629
GRAND TOTAL	4125	5530	5370	5797	6377	7016	7718

<sup>1</sup> Includes funds for decontamination of reactor facilities as per Table 3.

FIGURE 7

### GENERAL FUNDING DISTRIBUTION BY PROGRAMS

